



KUSTOM FIBERGLASS LIDS

visit our website: www.gaylordslids.com

Installation Instructions for 1964-87 El Camino and 1970-79 Ford Ranchero

WARNING: If you are not familiar with the use of hand tools or are not accustomed to working on motor vehicles, have a dealer or accessory shop install the Kustom Lid. Carefully read all the instructions prior to attempting to fit the Lid. Before fitting the Lid, part the vehicle on level ground in a well lit area and apply the emergency brake. After installation, check that the Lid works correctly and securely locks shut. Periodically check all fasteners for tightness. Retighten only the loose fasteners. When using power or hand tools, always wear the correct protective clothing recommended by the tool manufacturer.

Parts List:

In addition to the Lid, check to make sure that you received everything listed or shown here. If any parts are missing contact your dealers or Gaylord's.



2 Lid lifter shocks

IMPORTANT: A rain gutter is NOT included with the '64 through '67 El Caminos.

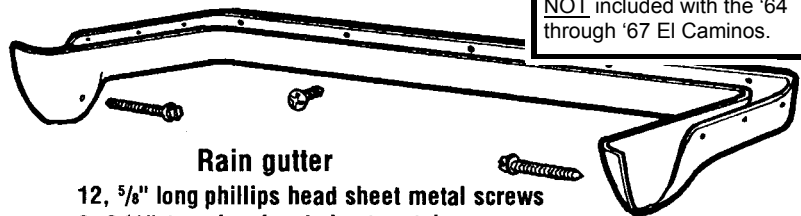

Rain gutter

- 12, 5/8" long phillips head sheet metal screws
- 2, 2 1/2" long hex head sheet metal screws

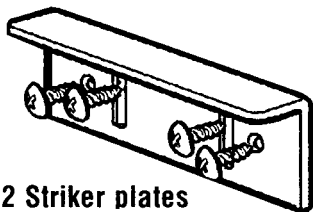

2 Striker plates

- 8, 5/8" long round head sheet metal screws

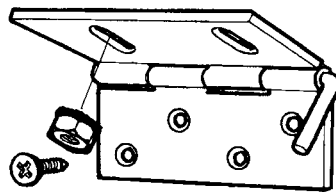

2 Front hinges

('73-'87 El Camino, all Rancheros)

- 4, 5/16" star nuts
- 8, 5/8" long flat head sheet metal screws

Quick release hinge pin

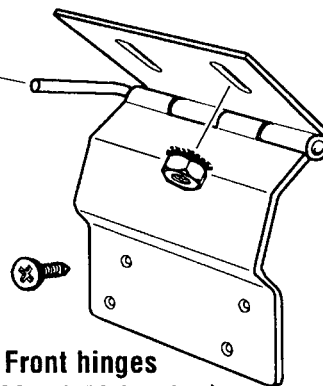

2 Front hinges

('68-'72 El Camino)

- 4, 5/16" star nuts
- 8, 5/8" long flat head sheet metal screws

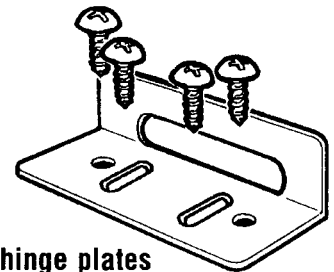

2 Front hinge plates

('64-'67 El Camino)

- 8, 5/8" long round head sheet metal screws

Tools Required:

- Power Drill, AC or Cordless
- 1/16", 1/8", 3/16", & 1/4" high speed drill bits
- 3/8" combination wrench
- 2 -- 17 mm combination wrenches
- #2 Phillips head screwdriver
- Flash light
- Tape measure
- Masking tape

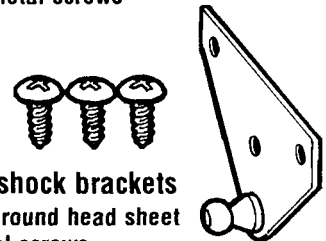

2 Lower shock brackets

- 8, 5/8" long round head sheet metal screws

Note: on '68-'72 El Camino's, install the front hinges, shock brackets and locks BEFORE installing the raingutter

1 On 68-72 El Camino's, installing hinge brackets

The special design of the hinge bracket enables it to fit over the window weatherstrip. With the help of another person, position lid on truck bed as desired. Lift lid at back and open tail gate, lower lid to original position. With flashlight, crawl into truck bed. Loosen the nuts securing the hinges to the lid. Move hinges so they are snug and square against the truck bed. Tighten the hinge nuts. Using the hinges as a guide, drill the truck bed for the 5/8" sheet metal screws. Attach hinge plates to truck using the 8, 5/8" sheet metal screws. At this stage, you can go on to step #5, or remove the quick release pins and lid then install the rain gutter as shown in section #2 below and re-attach the lid after.

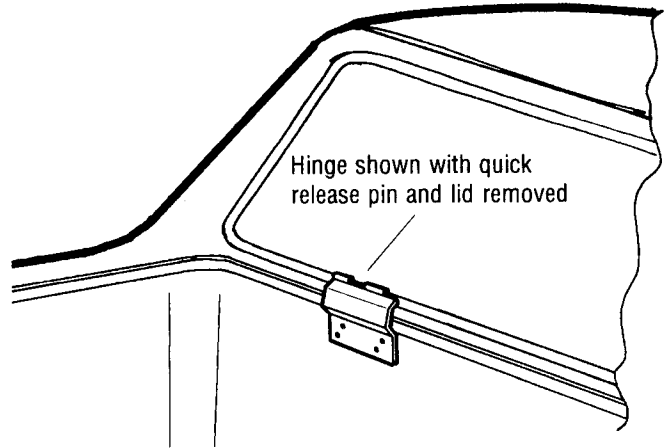

2 Installing the Rain Gutter

Center the rain gutter at the front of the truck bed as shown in the drawings. Use 1/8" drill, drill center of rain gutter and front of bed. Secure the gutter with 1 phillips head 5/8" sheet metal screw. Holding the back part of the gutter snugly against the wheel well, mark on the wheel well the location of the rain gutter. Repeat for other side. Remove gutter, drill 1/4" holes in the wheel well (see below). These holes should be to the gutter side of the line showing the location of the gutter.

These holes allow the water in the rain gutter to drain out through the wheel wells.

Attach rain gutter with center screw. Hold back of gutter snugly against the wheel wells. Drill 1/8" hole in trough and wheel wells. Secure rain gutter with the 2, 2 1/2" hex head sheet metal screws.

Secure the rain gutter with the remaining 5/8" phillips head sheet metal screws.

NOTE: 1964 - 1967 El Camino kits do not have drainage troughs

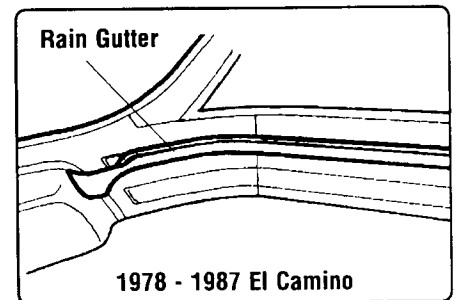
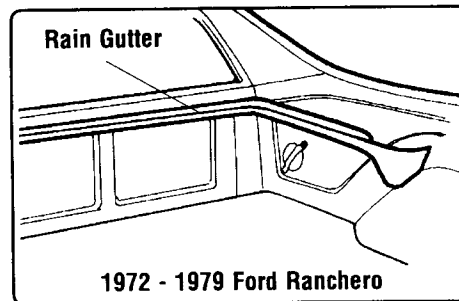
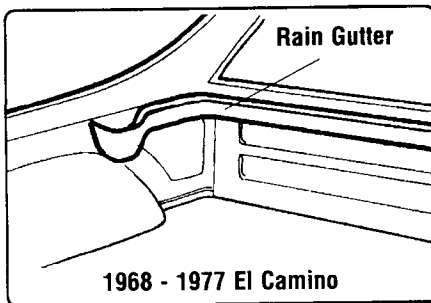

3 Weather sealing the rain gutter

Due to variations in manufacturing, there will be gaps and spaces between the rain gutter and the wheel wells. These should be filled with Silicon Sealer after the gutter has been installed. The heads of the two long sheet metal screws and where they screw into the wheel well should also be sealed. Seal both the bottom of the gutter at the wheel wells and along the top where it is attached to the truck bed.

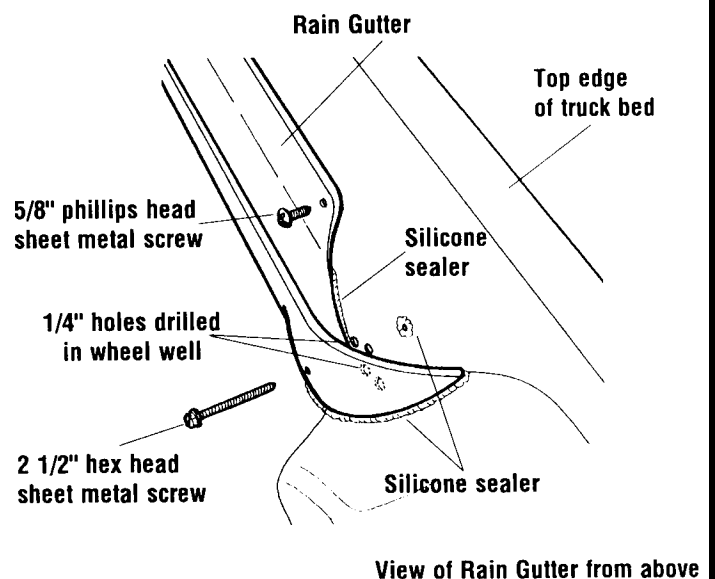
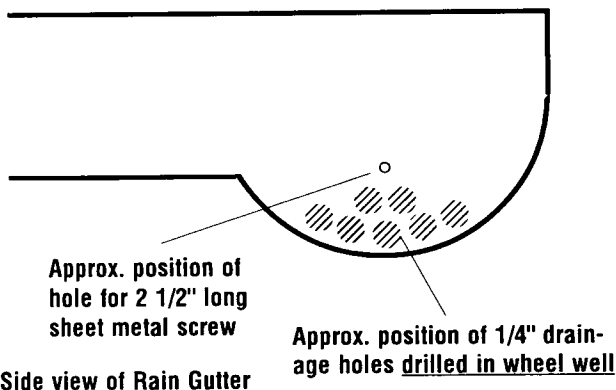

4 Marking for front hinge plates ('64-'67 El Camino)

With the assistance of another person, position lid on truck bed. Lid should fit square and be evenly spaced about the truck. The rear of the lid should be snug against the tailgate. Using the hinges in the lid, mark (with pencil) the positions for the hinge plates, see diagram below and right. The "A" marks will determine the lateral positioning if the lid. Remove the lid, using the marks, drill holes for sheet metal screws and attach the hinge plates to the truck.

Lid snug against tailgate

View from above truck

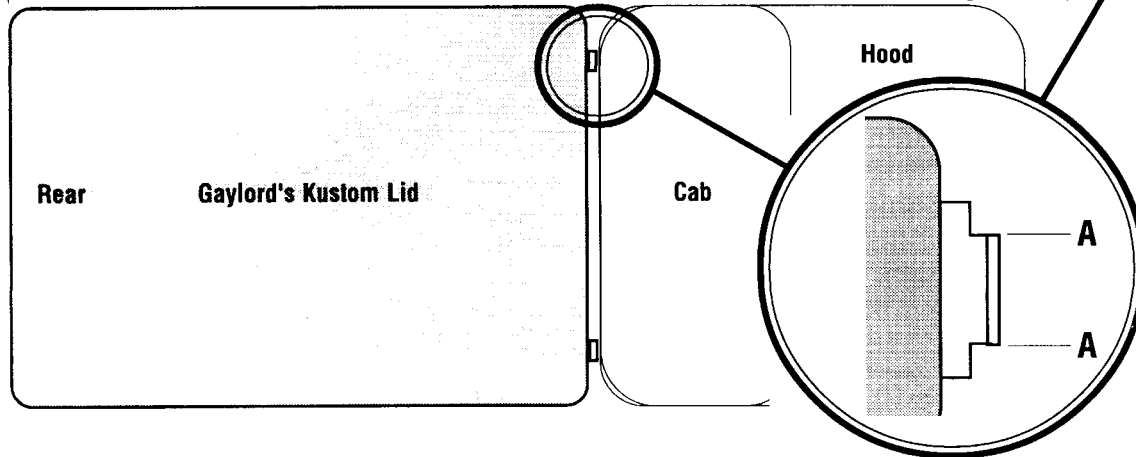

4A Attaching hinges to truck ('73-'87 Camino, Rancheros)

With the help of another person, position lid on truck bed as desired. Lift lid at back and open tail gate, lower lid to original position. With flashlight, crawl into truck bed. Loosen the nuts securing the hinge to the lid. Move hinges so they are snug and square against the truck bed. Tighten the hinge nuts. Using the hinges as a guide, drill the truck bed for the 5/8" sheet metal screws. Attach hinge plates to truck using the 8, 5/8" sheet metal screws.

Shock bracket on lid Mark location for the centers of lower shock bracket fixing screws

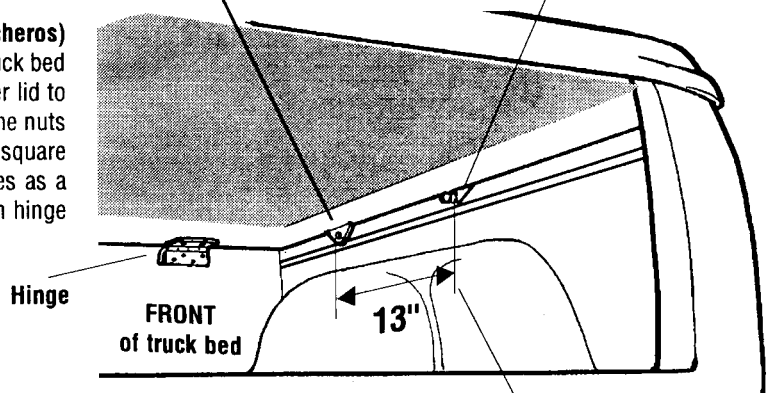

5 Mounting shock bracket

Lift lid at back and open tail gate, lower lid to original position. With flashlight, crawl into truck bed and mark location for the lower shock brackets. Measure **BACK** from the shock bracket on the lid 13 inches, this will be the center for the lower shock bracket.

Drill 2, 1/8" holes where you marked the centers for each of the lower shock mount brackets.

Mount lower shock brackets using 5/8" phillips head sheet metal screws. Attach the lift shocks to the brackets (they snap into place over the ball part of the brackets).

With the help of an assistant, attach the lid to the front hinge plates. With the lid in the open position, snap the lift shocks to the brackets on the lid.

Center of lower shock bracket
13" to the REAR of upper bracket on lid

View from rear of truck bed with the lid in position and the tailgate down

See over for further installation instructions

6 Mounting the lock striker plates

Open the tailgate, lower the lid with the locks in the unlocked position. When the lid is down, turn the locks to the locked position. Use a pencil to mark the center of the lock cam on both sides of the truck bed. Unlock the locks and raise the lid. Attach the striker plates to the sides of the bed with the 5/8" sheet metal screws. The center of the plate aligning with the center of the pencil mark.

With the tailgate still open, lower the lid with the locks in the unlocked position. Turn the locks to the locked position and adjust the nuts so that the lock cam exerts a small amount of pressure on the striker plate. Using two wrenches, cinch up the lock nut on the lock. Repeat on the other side. Unlock and open the lid.

Note: if the lock cam is not long enough to reach the striker plate or only just touches, turn the cam around on the lock, one leg is longer than the other.

With the lid open and the locks in the locked position, adjust the lock cam support so it just touches the underside of the lock cam. Using two wrenches, cinch up the lock nut on the lock cam support. Repeat on the other side. Turn the locks to the unlocked position. Close the tail gate, lower the lid with the locks in the unlocked position and check the locking and fit of the lid.

IMPORTANT:

7 Check all fastenings

Check that all the fasteners are secure and that the lid operates correctly. Check the locks securely hold the lid in the closed position. Make sure when the lid opens and closes, it does not scrape against any of the vehicle body work. You are now ready to enjoy the benefits of a Gaylord's Kustom Lid

WARNING:The locks must always be in the unlocked position before closing the lid. Failure to do this will result in scratched paint and damage to the locks.

WARNING! THIS TRUCK LID CAN BE HAZARDOUS IF INSTALLED OR OPERATED INCORRECTLY.

Read the instructions prior to installing or operating the lid. SEVERE INJURY can result if you do not follow these instructions and warnings. **Please read this carefully.**

- Always open the truck lid fully before reaching into the truck bed. The lid may accidentally close if not fully opened.

- Never place or carry items on the top of the truck lid.
- Never install any accessories on the truck lid.

The lifting forces generated and that act on the lid when the truck is moving may cause the lid to lift and may cause it to disengage from the truck. To prevent this, keep the following points in mind:

- Always close and lock the lid when driving the truck.
- Always close and lock the lid even when towing the truck.
- Always close and lock the lid when transporting the truck on a flatbed tow truck and **NEVER** transport the truck with the rear of the truck pointing in the direction of travel.

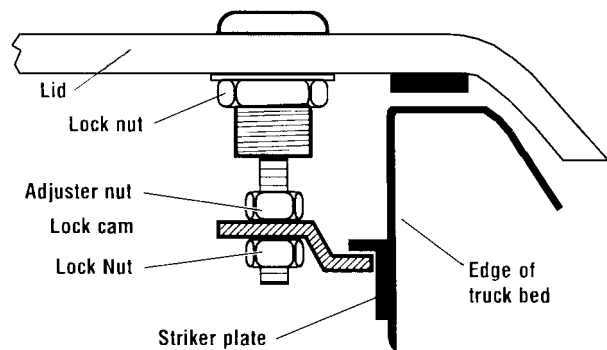
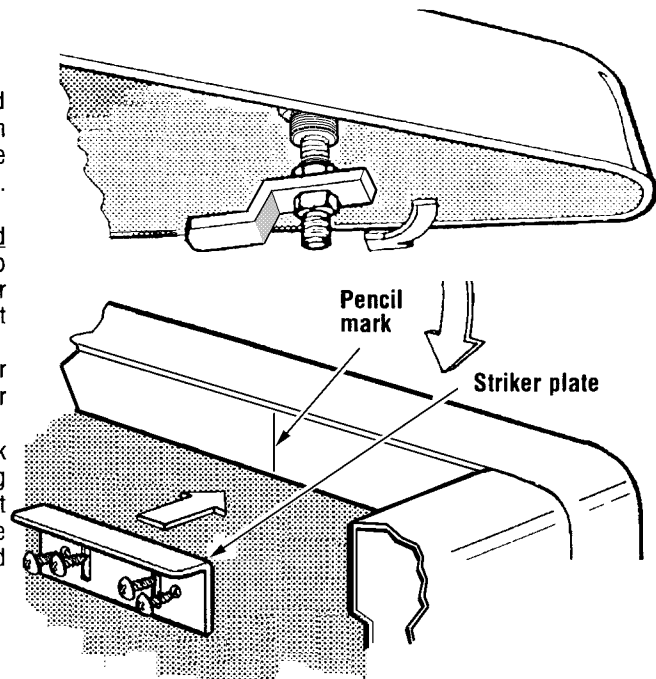

Lid removal

Gaylord's Kustom Lids are designed to be easily removed. With the lid open, detach the shock ends from the shock brackets (see diagram). With the help of an assistant, continue lifting lid until it detaches from the front hinge brackets (on '68-'87 El Caminos and all Rancheros, remove the quick release hinge pin).

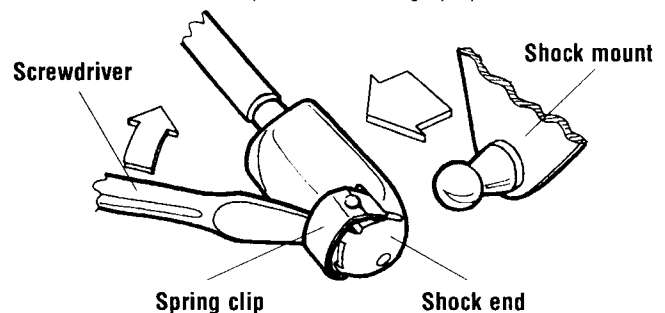

Removing lift shocks from shock mounts

Use screwdriver blade to lift spring clip away for the shock end (**do not** totally remove clip). Pull shock end away from shock mount, release the spring clip.

'68 - '72 El Caminos

IMPORTANT

To keep water from getting into the truck bed you must use a waterproof caulking compound between the Hinge and the Trim & Front Bed Wall that it is mounted on. Also caulk between the Hinge and the water trough. This should keep water from seeping in around the Hinge.

