

UNIVERSAL SCISSOR LIFT EASY GRIP CLAMP-ON BRACKET INSTALLATION INSTRUCTIONS

NOTE: Gaylord's Inc. takes every step possible to ensure that our customers receive the finest, best fitting fiberglass truck lid on the market.

Allowable tolerances by truck bed manufacturer affect the fit your fiberglass lid. Variations in the fit also occur but are not limited to the following reasons: improper lid alignment during installation, misalignment of the truck bed to the cab, misalignment of the tailgate to the rear of the truck bed, distortion of the truck bed related to chassis, truck bed not being square and truck and truck bed age problems.

WARNING: If you are not familiar with the use of hand tools or not accustomed to working on motor vehicles, have a dealer or accessory shop install Gaylord's Easy Grip Clamp On Lid. Carefully read all the instructions prior to attempting to fit the Lid. Before fitting the Lid, park the vehicle on level ground in a well lit area and apply the emergency brake. After installation, check that the Lid works correctly and securely locks shut. Periodically check all fasteners for tightness. Retighten only loose fasteners. When using power or hand tools, always wear the correct protective equipment recommended by the tool manufacturers.

GIS-62 © Gaylord's Inc. 10/2006

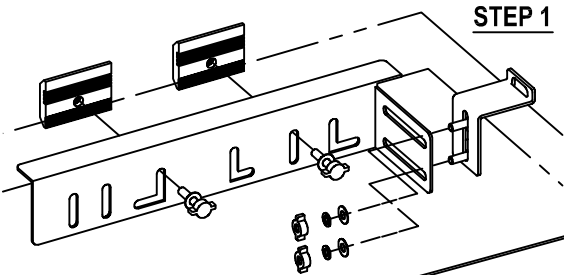

STEP 1

MOUNT THE FRONT HINGE BRACKETS WITH THE SPECIAL BOLTS. DON'T TIGHTEN FIRMLY UNTIL AFTER LID IS INSTALLED.

STEP 2

INSTALL THE STRIKER & SCISSOR LIFT MOUNTING BRACKETS AFTER LID IS INSTALLED. ADJUST ITS POSITION SO THE STRIKER ROD ENGAGES THE LATCH EASILY.

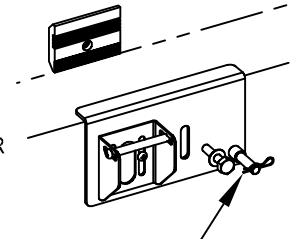

SCISSOR LIFT RETAILING CLIPS MUST BE INSTALLED IN ALL FOUR (4) ATTACHMENT POINTS!

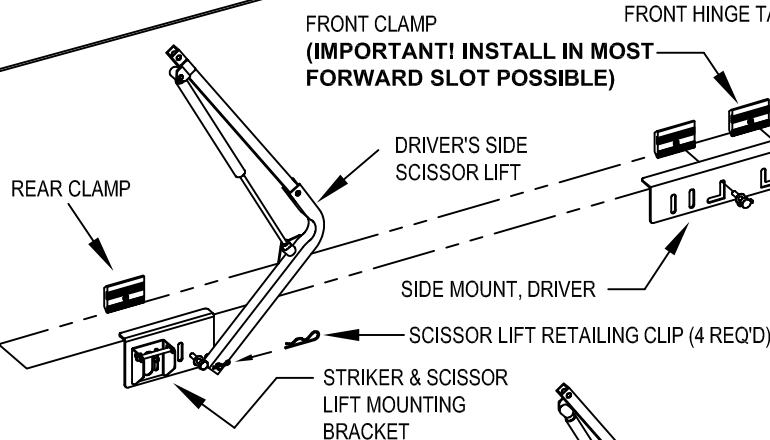

1. SPECIAL NUT, $\frac{5}{16}$ -18 (4)
2. WASHER, LOCK, $\frac{3}{16}$ (4)
3. WASHER, FLAT, $\frac{5}{16}$ (4)
4. CARRIAGE BOLTS, $\frac{5}{16}$ (4)

STEP 3 INSTALL AND ALIGN THE LID THEN TIGHTEN ALL FASTENERS WITH THE TAILGATE OPEN AND THE LID DOWN.

1. STRIKER BRACKET (2)
2. SCREWS & WASHERS (2 SETS)
3. BOLT (2)

SIDE MOUNT, PASSENGER

1. ALUMINUM CLAMP (4)
2. BOLT, M8 X 40 (4)
3. WASHER, M8 (4)

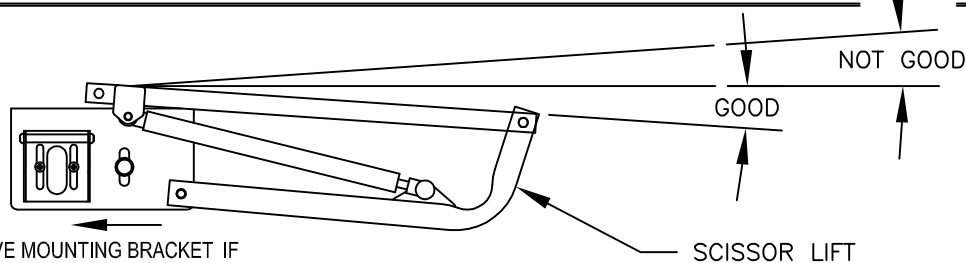

MOVE MOUNTING BRACKET IF LONG SCISSOR LIFT ARM IS IN THE "NO GOOD" ZONE.

SCISSOR LIFT

STEP 4

AFTER THE STRIKER & SCISSOR LIFT MOUNTING BRACKETS ARE IN PLACE, INSTALL THE SCISSOR LIFTS WITH LID OPEN.

IF THE LONG SCISSOR LIFT ARM IS IN THE "NOT GOOD" ZONE, MOVE THE BRACKET SLIGHTLY TOWARDS THE REAR. RETIGHTEN ALL THE HARDWARE AFTER YOU ARE SATISFIED.

TOYOTA TOCOMA SCISSOR LIFT EASY GRIP II CLAMP-ON BRACKET INSTALLATION INSTRUCTIONS

NOTE: Gaylord's Inc. takes every step possible to ensure that our customers receive the finest, best fitting fiberglass truck lid on the market.

Allowable tolerances by vendors & truck bed manufacturer affect the fit your fiberglass lid. Variations in the fit also occur but are not limited to the following reasons: improper lid alignment during installation, misalignment of the truck bed to the cab, misalignment of the tailgate to the rear of the truck bed, distortion of the truck bed related to chassis, truck bed not being square and truck and truck bed age problems. Please note, that the gas springs force varies with weather temperature.

WARNING: If you are not familiar with the use of hand tools or not accustomed to working on motor vehicles, have a dealer or accessory shop install Gaylord's Easy Grip Clamp On Lid. Carefully read all the instructions prior to attempting to fit the Lid. Before fitting the Lid, park the vehicle on level ground in a well lit area and apply the emergency brake. After installation, check that the Lid works correctly and securely locks shut. Periodically check all fasteners for tightness. Retighten only loose fasteners. When using power or hand tools, always wear the correct protective equipment recommended by the tool manufacturers.

GIS-64 © Gaylord's Inc. 10/2006

STEP 1B MOUNT THE FRONT HINGE BRACKETS WITH THE SPECIAL BOLTS. DON'T TIGHTEN FIRMLY UNTIL AFTER LID IS INSTALLED.

STEP 1A INSTALL THE "D" BULB SEAL FIRST.

STEP 2

INSTALL THE STRIKER & SCISSOR LIFT MOUNTING BRACKETS AFTER LID IS INSTALLED. ADJUST ITS POSITION SO THE STRIKER ROD ENGAGES THE LATCH EASILY.

SCISSOR LIFT RETAINING CLIPS MUST BE INSTALLED IN ALL FOUR (4) ATTACHMENT POINTS!

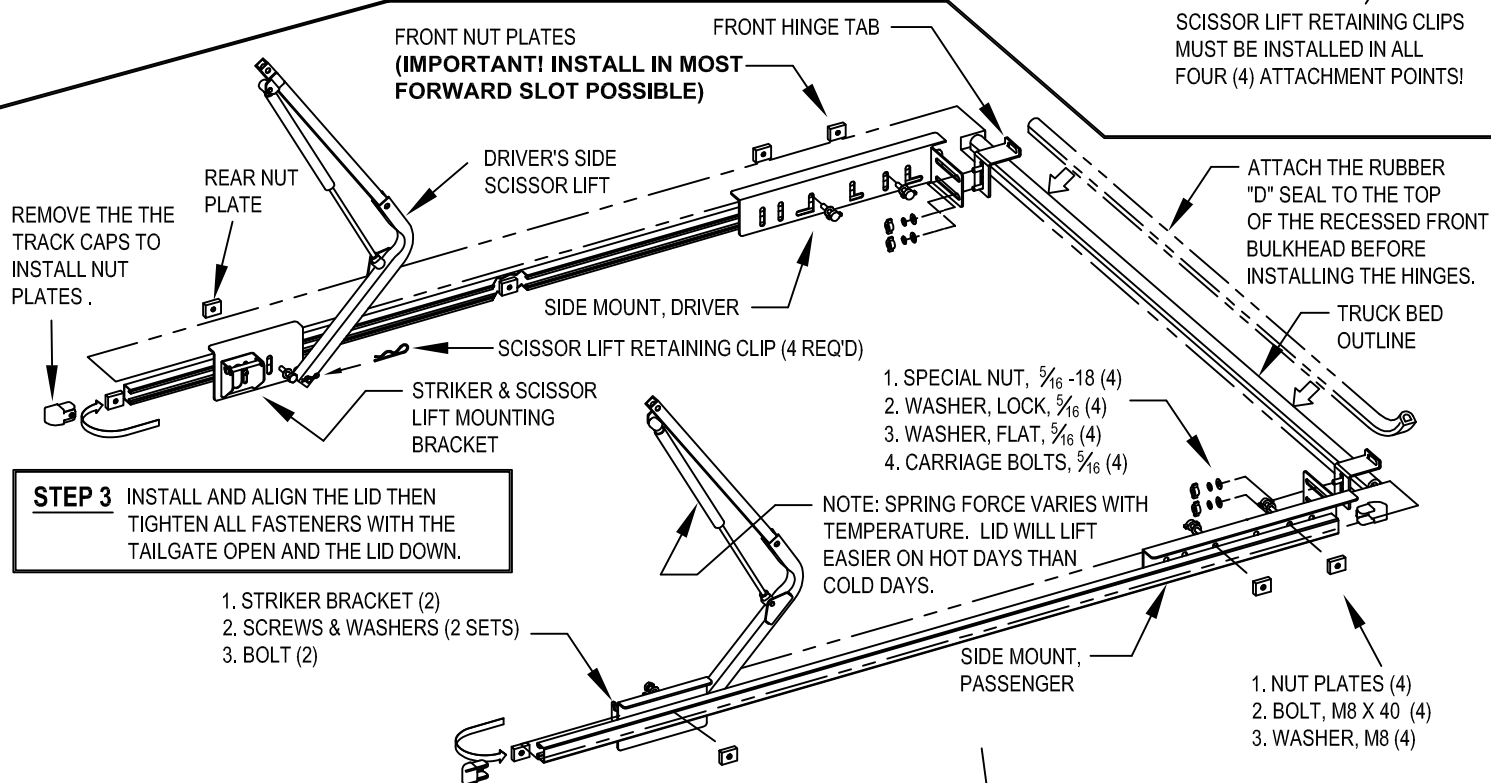

STEP 3 INSTALL AND ALIGN THE LID THEN TIGHTEN ALL FASTENERS WITH THE TAILGATE OPEN AND THE LID DOWN.

1. STRIKER BRACKET (2)
2. SCREWS & WASHERS (2 SETS)
3. BOLT (2)

STEP 4

AFTER THE STRIKER & SCISSOR LIFT MOUNTING BRACKETS ARE IN PLACE, INSTALL THE SCISSOR LIFTS WITH LID OPEN.

IF THE LONG SCISSOR LIFT ARM IS IN THE "NOT GOOD" ZONE, MOVE THE BRACKET SLIGHTLY TOWARDS THE REAR. RETIGHTEN ALL THE HARDWARE AFTER YOU ARE SATISFIED.

MOVE MOUNTING BRACKET IF LONG SCISSOR LIFT ARM IS IN THE "NO GOOD" ZONE.

GOOD

NOT GOOD

SCISSOR LIFT



'05 YTD NISSAN FRONTIER EASY GRIP II CLAMP-ON BRACKET INSTALLATION INSTRUCTIONS

NOTE: Gaylord's Inc. takes every step possible to ensure that our customers receive the finest, best fitting fiberglass truck lid on the market.

Allowable tolerances by vendors & truck bed manufacturer affect the fit your fiberglass lid. Variations in the fit also occur but are not limited to the following reasons: improper lid alignment during installation, misalignment of the truck bed to the cab, misalignment of the tailgate to the rear of the truck bed, distortion of the truck bed related to chassis, truck bed not being square and truck and truck bed age problems. Please note, that the gas springs force varies with weather temperature.

WARNING: If you are not familiar with the use of hand tools or not accustomed to working on motor vehicles, have a dealer or accessory shop install Gaylord's Easy Grip Clamp On Lid. Carefully read all the instructions prior to attempting to fit the Lid. Before fitting the Lid, park the vehicle on level ground in a well lit area and apply the emergency brake. After installation, check that the Lid works correctly and securely locks shut. Periodically check all fasteners for tightness. Retighten only loose fasteners. When using power or hand tools, always wear the correct protective equipment recommended by the tool manufacturers.

GIS-65 © Gaylord's Inc. 11/2006

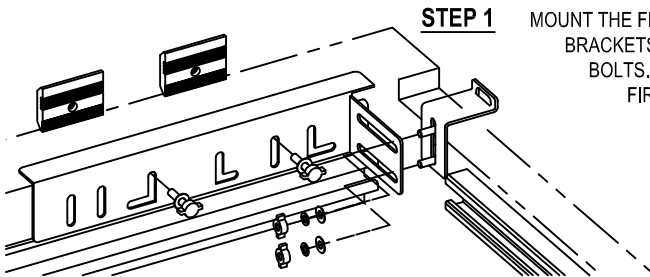

STEP 1 MOUNT THE FRONT HINGE BRACKETS WITH THE SPECIAL BOLTS. DON'T TIGHTEN FIRMLY UNTIL AFTER LID IS INSTALLED.

STEP 2 INSTALL THE STRIKER & SCISSOR LIFT MOUNTING BRACKETS AFTER LID IS INSTALLED. ADJUST ITS POSITION SO THE STRIKER ROD ENGAGES THE LATCH EASILY.

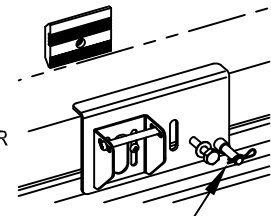

SCISSOR LIFT RETAINING CLIPS MUST BE INSTALLED IN ALL FOUR (4) ATTACHMENT POINTS!

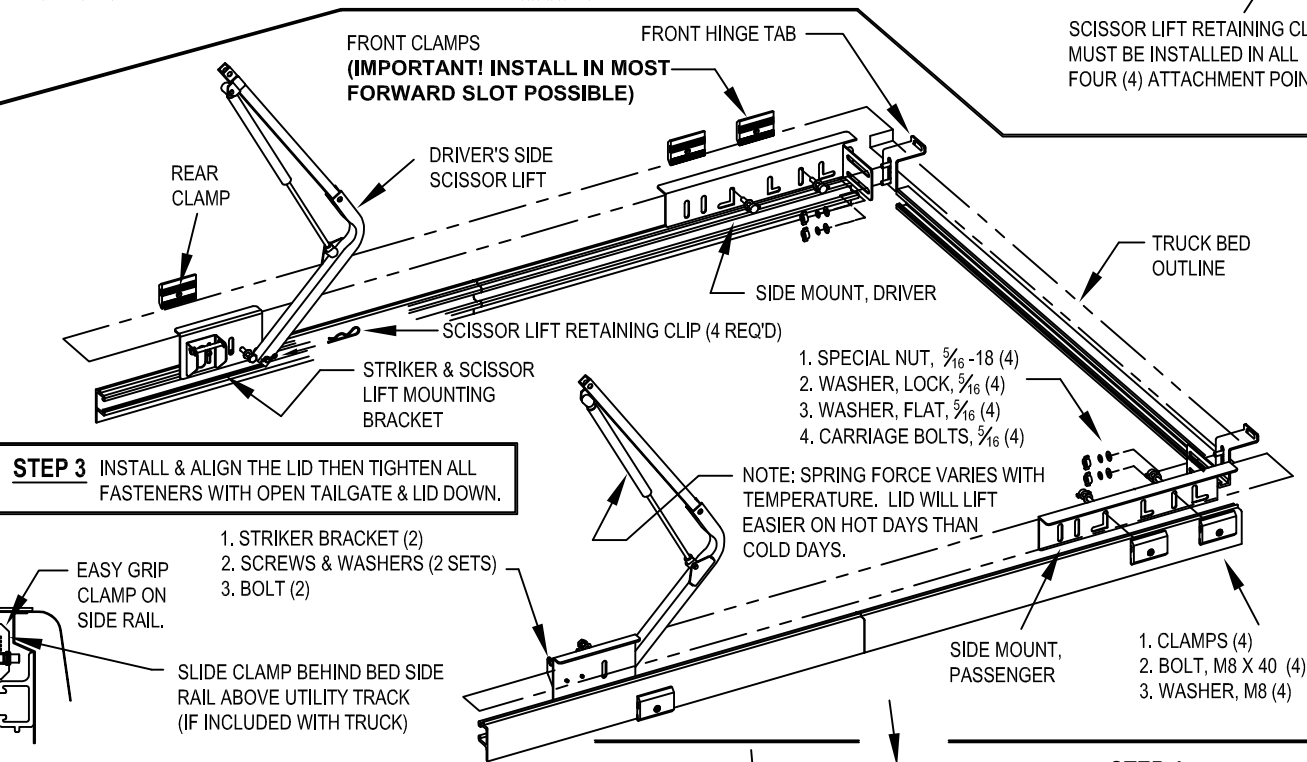

STEP 3 INSTALL & ALIGN THE LID THEN TIGHTEN ALL FASTENERS WITH OPEN TAILGATE & LID DOWN.

1. STRIKER BRACKET (2)
2. SCREWS & WASHERS (2 SETS)
3. BOLT (2)

EASY GRIP CLAMP ON SIDE RAIL.

SLIDE CLAMP BEHIND BED SIDE RAIL ABOVE UTILITY TRACK (IF INCLUDED WITH TRUCK)

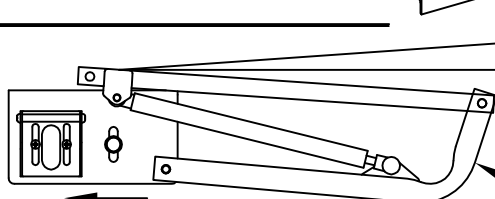

MOVE MOUNTING BRACKET IF LONG SCISSOR LIFT ARM IS IN THE "NO GOOD" ZONE.

NOT GOOD

GOOD

SCISSOR LIFT

STEP 4

AFTER THE STRIKER & SCISSOR LIFT MOUNTING BRACKETS ARE IN PLACE, INSTALL THE SCISSOR LIFTS WITH LID OPEN.

IF THE LONG SCISSOR LIFT ARM IS IN THE "NOT GOOD" ZONE, MOVE THE BRACKET SLIGHTLY TOWARDS THE REAR. RETIGHTEN ALL THE HARDWARE AFTER YOU ARE SATISFIED.

MOD KIT 2207-D

© 2006, GAYLORD'S, INC.

1. EXPOSE THE ADHESIVE TAPE.
2. PLACE THE ANGLE BETWEEN THE BED CAP AND THE BED RAIL.

INSTALL THE CLAMPS SO ONE OF THE GROOVES LINES UP WITH THE SMALL FLANGE ON THE ANGLE.

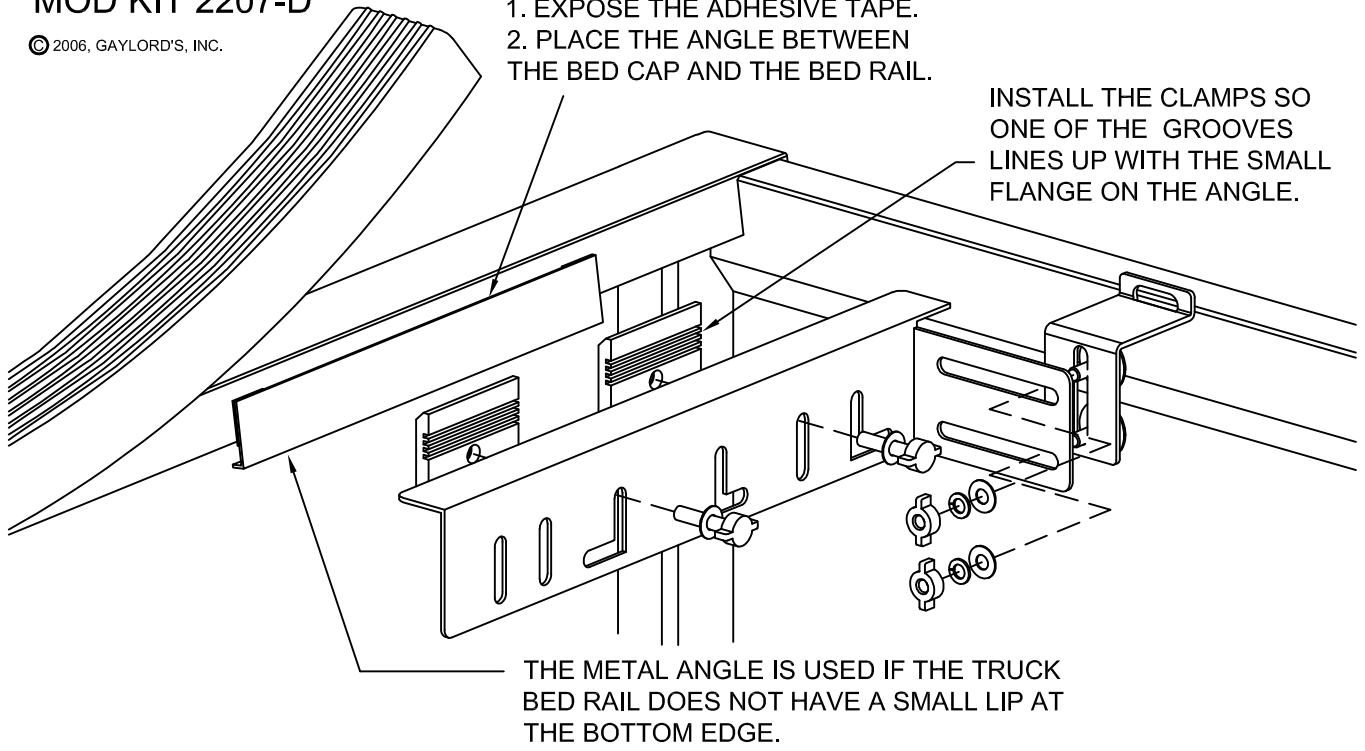

MOD KIT 2207-D

© 2006, GAYLORD'S, INC.

1. EXPOSE THE ADHESIVE TAPE.
2. PLACE THE ANGLE BETWEEN THE BED CAP AND THE BED RAIL.

INSTALL THE CLAMPS SO ONE OF THE GROOVES LINES UP WITH THE SMALL FLANGE ON THE ANGLE.

