

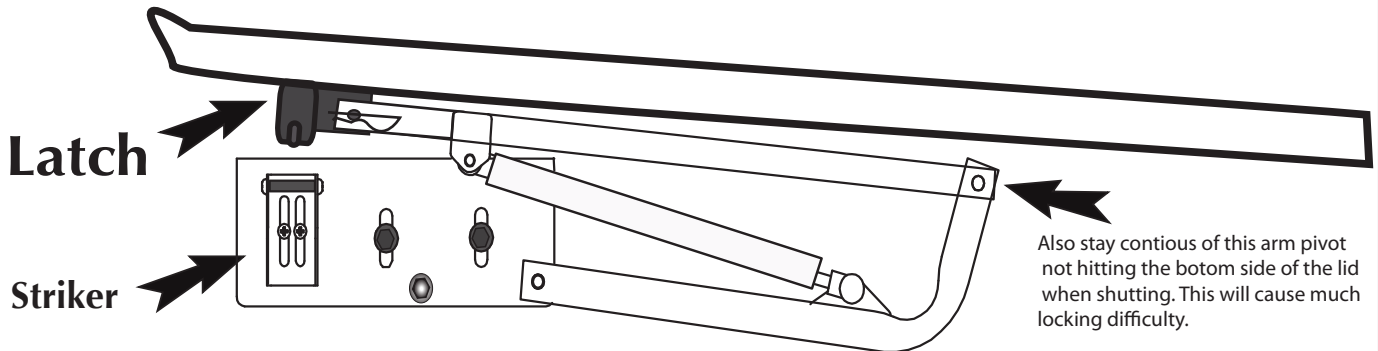

PLEASE SUPPLY THIS TO YOUR CUSTOMER!

please visit us on the web for any additional Info @ WWW.GAYLORDSLIDS.COM

Gaylord's Lids would like to thank you for your recent custom fiberglass bed cover purchase. We greatly appreciate your business and would like to share with you, easy do-it-yourself adjustments and normal maintenance for this custom lid.



ENSURING PROPER LATCH ALIGNMENT.

When installing the striker bracket to the bed side, disconnect the shock for ease of opening and closing the lid. You are verifying the latch is positioned dead center of the striker bar. If the latch is not centered, not only will the latch rub the sides of the striker housing, but the lid will not function properly. When centered perfectly you may clamp the striker down and adjust the kickstand. This will be the fixed location of the striker bracket.

STRIKER ADJUSTMENTS (SIDE VIEW)

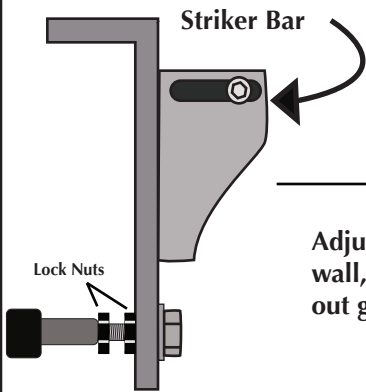

Adjusting the striker bracket is quick and easy. Drop the tailgate, close the lid down, and determine where the center of the latch will need to catch. The striker can easily move vertical and also forward/backwards. This must be done on every installation; Truck beds will vary slightly. Gaylord's suggests monthly inspection of these parts to ensure perfect locking and unlocking for the duration of ownership.

Adjusting the kickstand is simple. Using the Lock Nuts, position the rubber stopper against the bed wall, this ensures the striker bracket stays vertical on the truck bed. You may spin the stopper in or out gaining or taking away the brackets camber.

LATCH ADJUSTMENTS

There is one latch on either side of the lid. There is also a plastic cover over each latch. If you need to adjust the latches for a perfect synchronized unlocking, first remove the plastic covers then drop the tailgate. Each latch has a wire cable running to it and held in place with a small set screw (allen head) lock both latches, and slowly pull on the red emergency release in the center of the lid. Doing this slowly will help determine which latch cable needs to be tightened or which side needs some slack. (If your latch doesnt stay latched you will need to loosen the cable or call gaylord's to help walk you through ait)

Thanks! -Gaylord's Tech Dept.

WARNING: If you are not familiar with the use of hand tools or are not accustomed to working on motor vehicles, have a dealer or accessory shop install the Kustom Lid. Carefully read all the instructions prior to attempting to fit the Lid. Before fitting the Lid, park the vehicle on level ground in a well lit area and apply the emergency brake. After installation, check that the Lid works correctly and securely locks shut. Periodically check all fasteners for tightness. Retighten only the loose fasteners. When using power or hand tools, always wear the correct protective clothing recommended by the tool manufacturer.

